

QC20-W wireless ballbar system description and specifications



Hardware



Software

QC20-W ballbar and ballbar kit

QC20-W ballbar



The QC20-W ballbar contains a precision linear transducer of Renishaw's own design (patent applied for). It is used to measure variations in radius as the ballbar is rotated around a fixed point. This data is used to calculate overall measures of positioning accuracy (circularity, circular deviation) in accordance with international standards such as ISO 230-4 and ASME B5.54/57. It also provides a detailed diagnosis of contributing individual error sources when analysed using Renishaw's unique diagnostic report format. Data is displayed graphically as well as in numeric format to support diagnosis.

Signal processing is carried out within the ballbar and data transmitted to a suitable PC using a Bluetooth® Class 2 module. There is an LED status indicator built into the housing covering communications, battery and fault status indication.

A standard (non rechargeable) CR2 lithium ion battery is supplied with each unit, although the system electronics also allow for the use of rechargeable CR2 type batteries.

Zerodur® calibrator

A Zerodur® calibrator is supplied with all QC20-W kits and is used to calibrate the length of a ballbar. This type of calibrator is manufactured from a material which has a temperature expansion coefficient of almost zero.



When used with the Zerodur® calibrator, the QC20-W ballbar measures the absolute radius of the tested tool path. The ballbar can therefore be used to provide absolute (rather than relative) errors for axis scaling and radial deviation values as required for ISO 230-4 and ASME B5.54/57 analyses.

In addition the software will automatically calculate the positional tolerance of the tested machine. (The positional tolerance value is an estimate of the planar, bi-directional positioning accuracy of the machine, within the area enclosed by the ballbar test, and under unloaded conditions)

The Zerodur® calibrator can calibrate 100, 150 and 300 mm lengths. The small circle kit contains a 50 mm Zerodur® calibrator.

QC20-W ballbar kit

Kit contents

- QC20-W wireless ballbar (and one CR2 battery)
- Centre pivot
- Tool cup
- 50, 150 and 300 mm extension bars
- Zerodur® calibrator
- System software (including manuals)
- Offset setting ball
- Machine validation cards
- Calibration certificates
- System carry case (the case includes cut-outs for the optional small circle and VTL adaptors)



Testing capability

The standard QC20-W ballbar kit includes a 100 mm long ballbar assembly and 50, 150 and 300 mm long extension bars. By assembling the ballbar with different combinations of extension bars it is possible to carry out ballbar tests with 100, 150, 250, 300, 400, 450, 550 or 600 mm radii. With additional extensions it is possible to perform tests up to 1350 mm.

The optional small circle kit allows tests with a 50 mm radius and testing can also be carried out on two-axis machines and lathes using optional accessories (page 6).

Partial arc testing

Redesigned ball mounts (including new centre pivot and tool cup extension) allow the QC20-W to carry out a 220° arc test in planes through the centre pivot axis. This means that you can carry out ballbar tests in three orthogonal planes without the need to reposition the centre pivot, so speeding up testing.



The results can also be used in the new “volumetric analysis” report function (see software section) with the assurance that all data has been gathered around the same reference point.

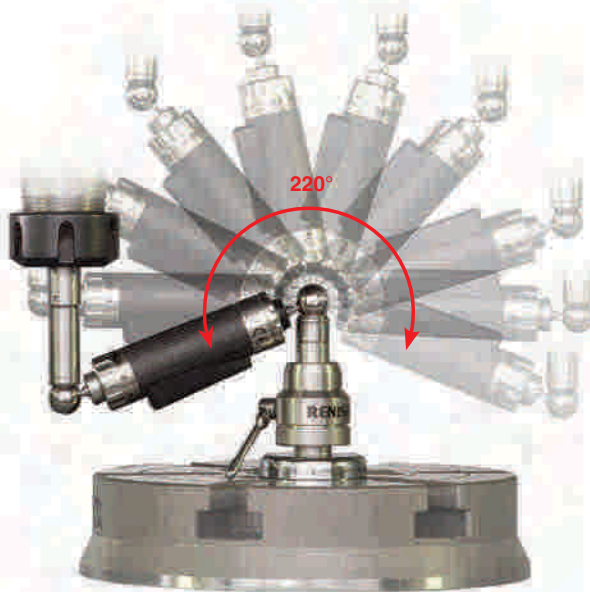

Certificates and recalibration

All QC20-W ballbars are delivered with a detailed calibration certificate; your guarantee of accuracy. This also gives full traceability details in accordance with ISO 17025 requirements. Machine shops can be an aggressive environment and accidents that affect the ballbar’s performance can happen. Periodic recalibration is therefore recommended to give you confidence that the ballbar is still measuring within specification. In typical use we would suggest yearly recalibration (see website for further details). Renishaw’s QC20-W calibration service includes inspection and testing of your ballbar, replacement of tool cups and balls, comparison against a laser reference standard, computation of a new scale factor, and issue of a certificate of accuracy and traceability.

System specification

Sensor resolution	0.1 µm (4 µin)
Ballbar sensor accuracy	±0.5 µm (at 20 °C) ±20 µin (at 68 °F)
Maximum sample rate	1000 values per second
Data transmission	Bluetooth, Class 2 (10 m typical)
Extension bars	50 mm, 150 mm, 300 mm
Operating range	0 °C - 40 °C (32 °F - 104 °F)
Calibrator accuracies (at 20 °C)	±1 µm (50 mm) ±1 µm (100 mm) ±1 µm (150 mm) ±1.5 µm (300 mm)
System case dimensions	(L x W x H) 395 mm x 300 mm x 105 mm
System case weight	3.75 kg (approx) incl. kit contents

Measurement and diagnosis software

Ballbar 20 software

Just like the QC20-W ballbar, Ballbar 20 software is powerful and easy to use. The intuitive interface and step-by-step instructions mean you can be using the system in minutes.

Key features are:

- Easy to use interface (Windows XP, Windows Vista®, Windows 7 compatible)
- Live data capture
- Analysis and display of test data in accordance with the latest ISO 230-4, JIS B 6190-4, B5.57 and B5.54 standards as well as extensive Renishaw analysis
- Positional tolerance value calculation
- Comprehensive, hyperlinked manual with hotlinks and search
- Multilingual support*
- Powerful file and template administration utilities

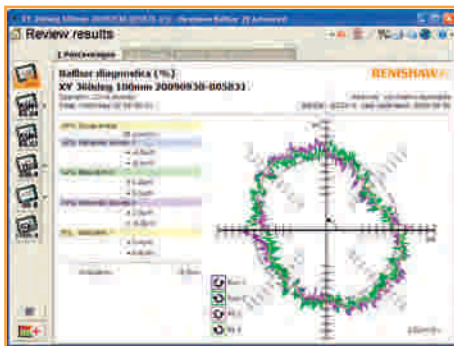

Integrated manual

Integrated manual, with hotlinks and search.

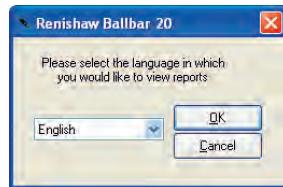

Multilingual support

Ballbar 20 allows multi-language report generation as well as a choice of operating language.*

In addition to a choice of standard test analysis functions, Ballbar 20 software includes:

Part program generator

This facility allows the automatic generation of a part program for the specific ballbar test. To create a part program, all the user has to do is define a ballbar test or select an existing test template, select a pre-defined CNC controller definition and then click the "generate" button.

The part program generated can be reviewed on-screen prior to printing or exporting to a removable storage device.

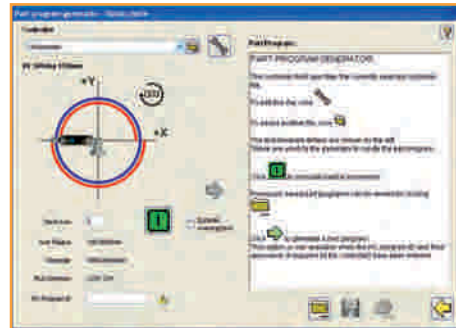

Machine history

The machine history function allows you to build and review a test history for any specific machine. Just choose a test template and then select some or all of the tests in the machine folder.

The machine history function allows the variations in the performance of your machine over time to be displayed graphically, using any of the standard report values.

You can clearly see how your machine's performance has varied and can even "interrogate" individual plot points back to the original test report and polar graph.

In short, review a complete "medical record" for your machine!

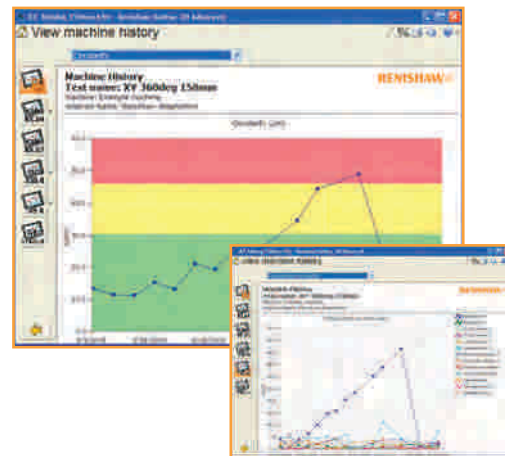

The software also allows you to:

- Set individual warning and failure performance bands for each machine characteristic
- Get instant notification, during the ballbar test, if a machine's performance exceeds these tolerances

* Available in English, German, French, Italian, Spanish, Chinese, Japanese, Czech, Korean, Russian and Polish.

System accessories

Small circle accessory kit

The small circle accessory kit is used with the QC20-W ballbar to allow tests with a radius of 50 mm. This can be useful when testing machine axes with short axis travel, or to emphasise the effects of servo and dynamic errors on the machine (small circles require higher machine accelerations and decelerations).

The kit includes a 50 mm Zerodur® calibrator (and calibration certificate) and the small circle adaptor, which is supplied with an additional centre ball already fitted. The adaptor is a simple screw fitting to the main ballbar body. The kit is not recommended for use with the lathe accessory. The adaptor is available separately for customers upgrading from QC10 to QC20-W who already have a small circle accessory kit.



Contents of QC20-W small circle accessory kit

VTL adaptor

For 2-axis CNC applications the VTL adaptor is available (this replaces the “tool cup” in the standard set-up and restricts movement of the centre cup to a single axis only.) This enables typical 2-axis machines such as vertical turning lathes and laser cutting machines etc, to benefit from QC20-W ballbar diagnosis.

With the zero position coordinates set, the VTL accessory allows for one magnetic cup to be withdrawn (to allow it to be driven to the test start position using the free axes’ motion) and then be pulled forward (to the third axis zero position) without introducing any offset error in the other two axes.

The schematic below shows a typical application on a VTL where the tool head always runs along the Y axis on the centre-line of the rotary axis.

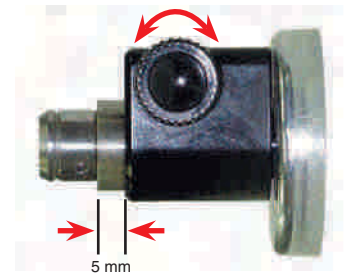

VTL adaptor restricts movement of the magnetic cup to 5 mm in one axis only.

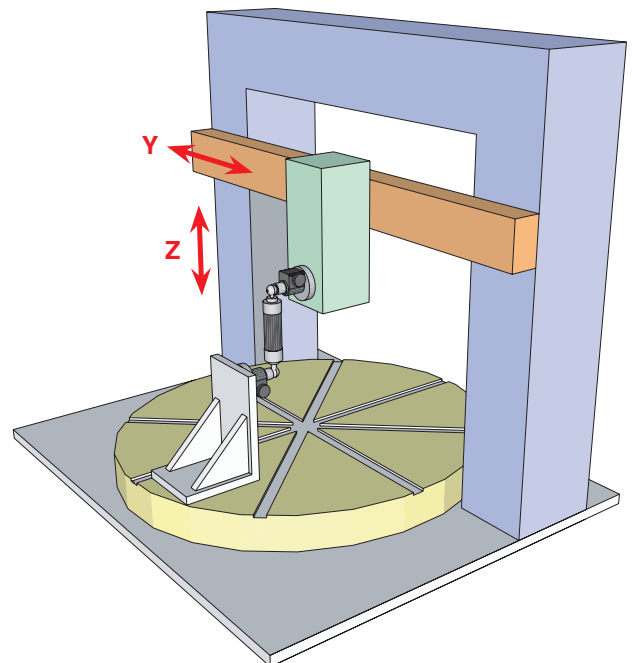
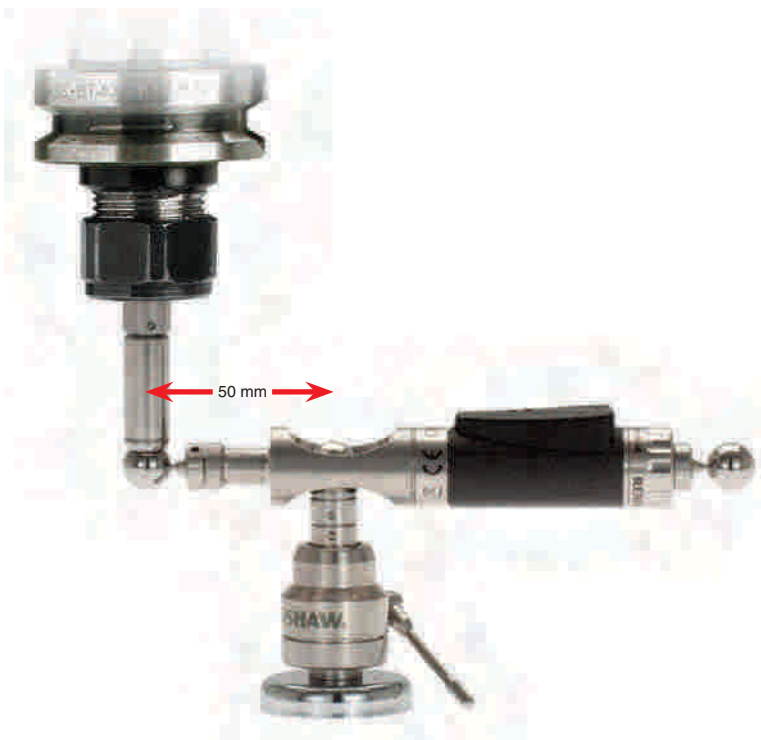

Typical two-axis vertical turning lathe showing VTL adaptor on tool holder.